

**MINISTARSTVO TURIZMA  
PROMOCIJA I JAČANJE KOMPETENCIJA  
STRUKOVNIH ZANIMANJA  
ZA TURIZAM**

**2014.**



**GASTRO-RAŠLJE**

**STROJARSKA TEHNIČKA ŠKOLA OSIJEK**

# Ciljevi koji se postižu provedbom projekta

- Provedbom projekta povećava se gastronomska ponuda kontinentalne hrvatske koja je jedna od 10 ključnih turističkih proizvoda u Strategiji razvoja RH do 2020.
- Uključivanjem NEturističkog sektora u razvoj turizma kontinentalne Hrvatske povećava se i potiče inovativnost i poduzetnički duh te ostvaruje suradnja sa drugim dionicima u turizmu.

# Faze izrade projekta

- Projektiranje proizvoda – rašlje od nehrđajućeg lima
- Izrada prototipa proizvoda
- Testiranje prototipa GASTRO-rašlji
- Izrada serije GASTRO-rašlji od nehrđajućeg čelika
- Prezentacija proizvoda

# Projektiranje proizvoda – skice idejnog rješenja

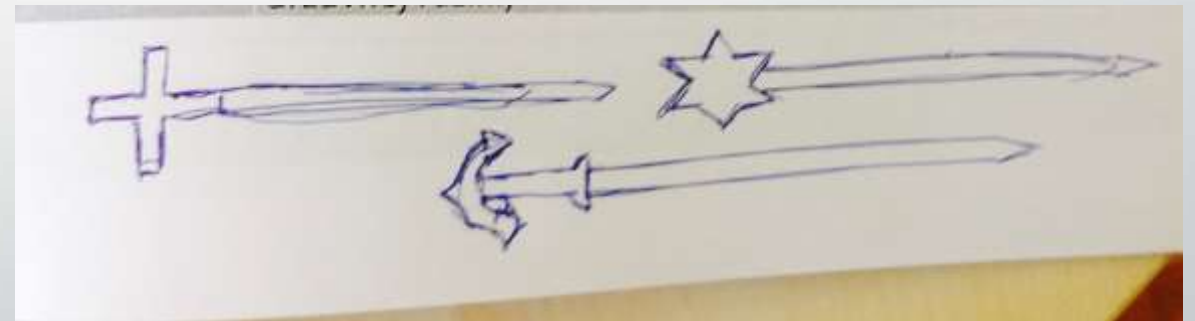
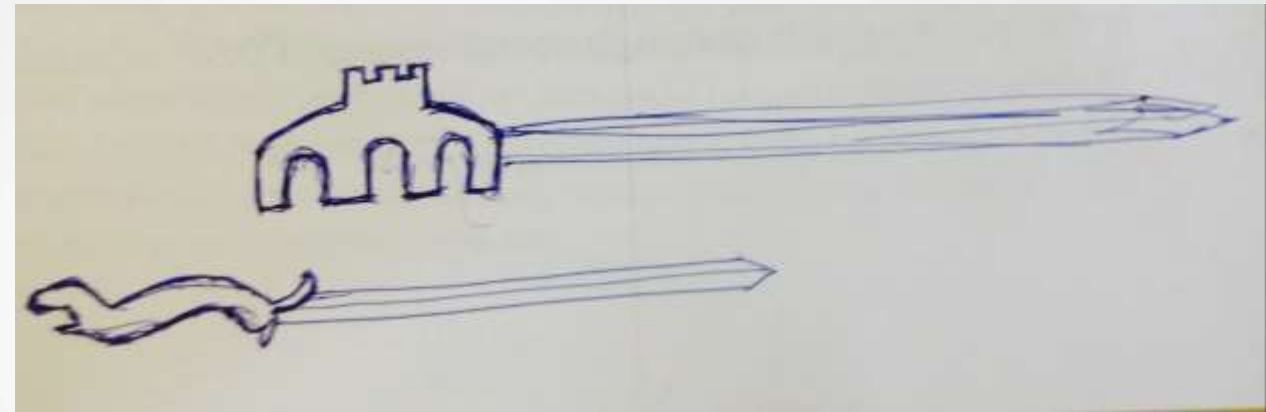
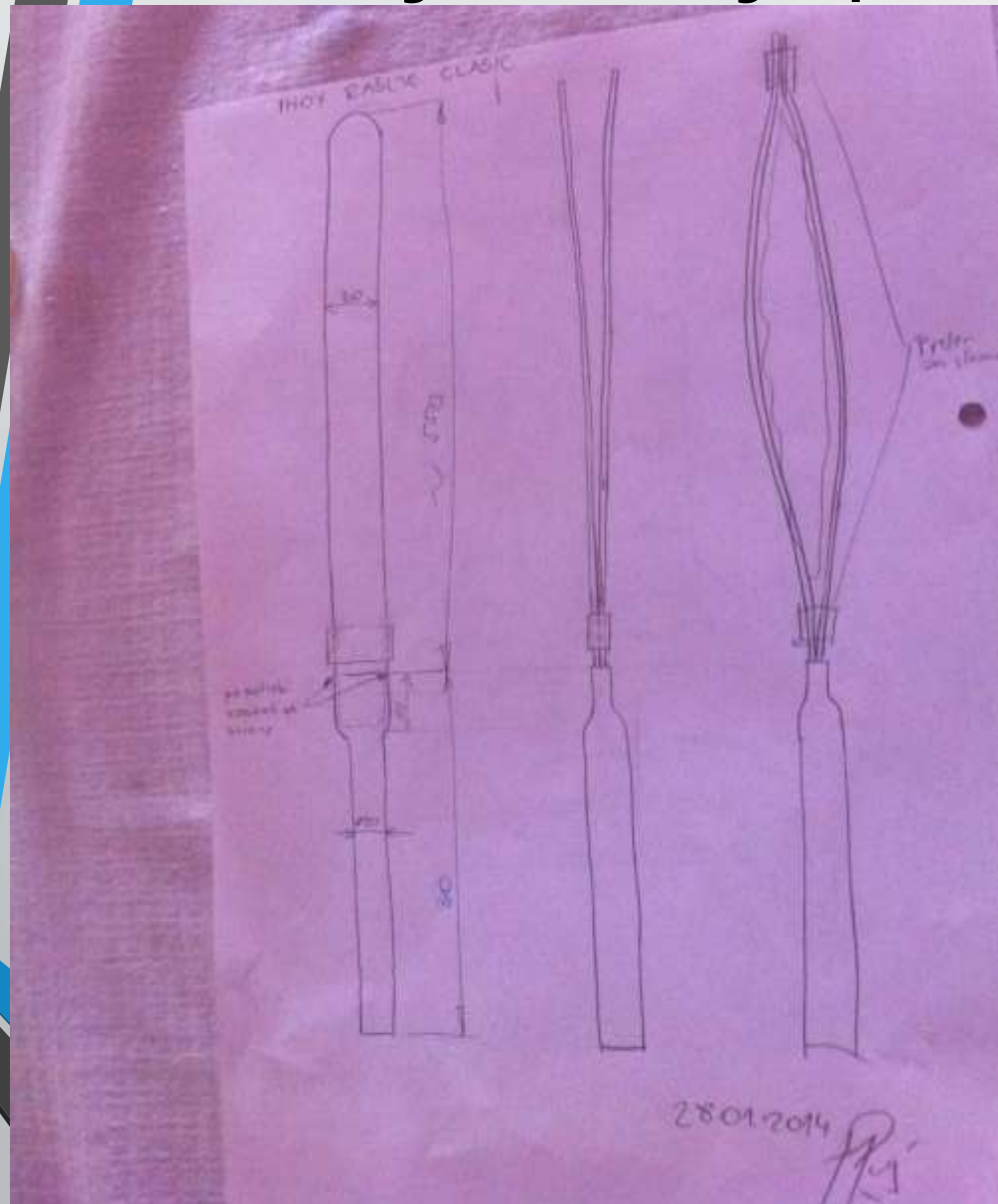



# Projektiranje proizvoda – CATIA

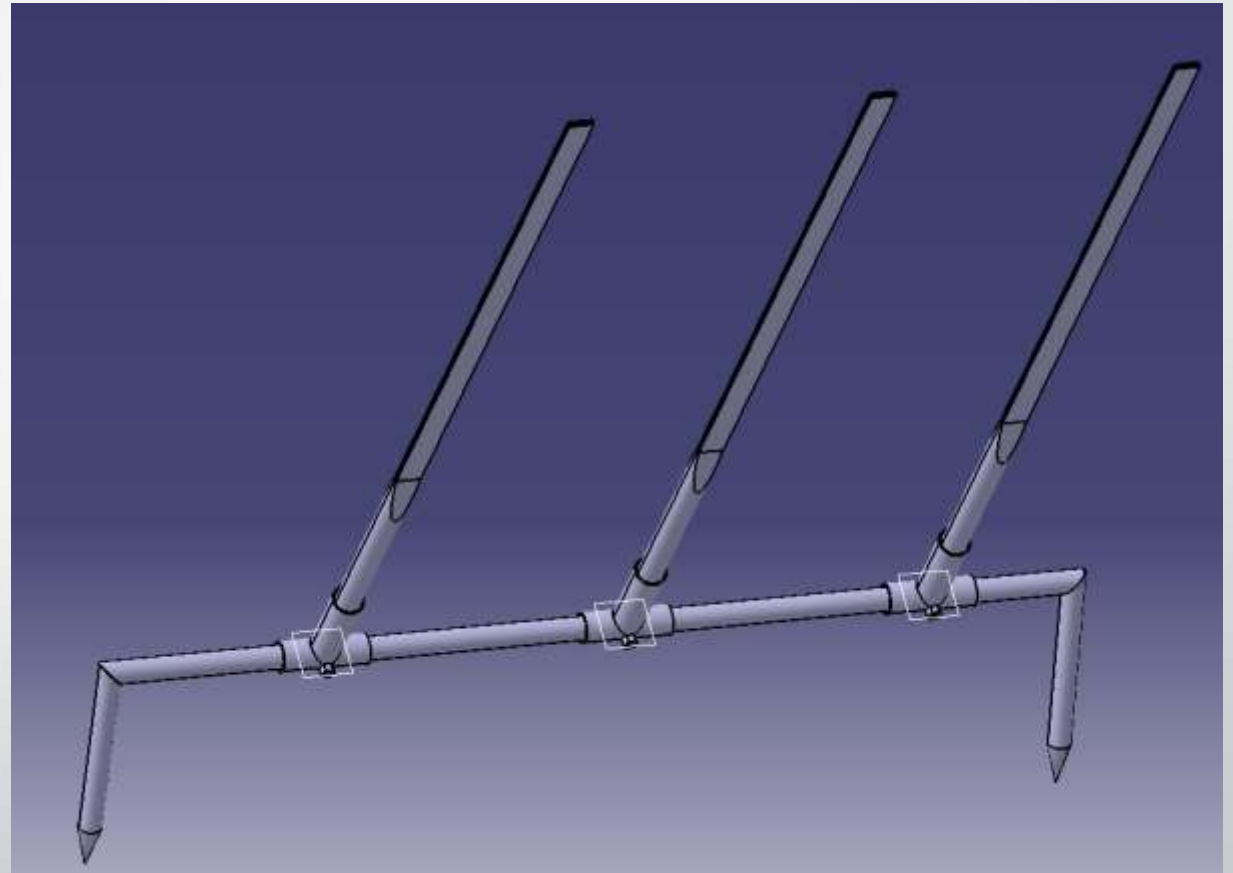
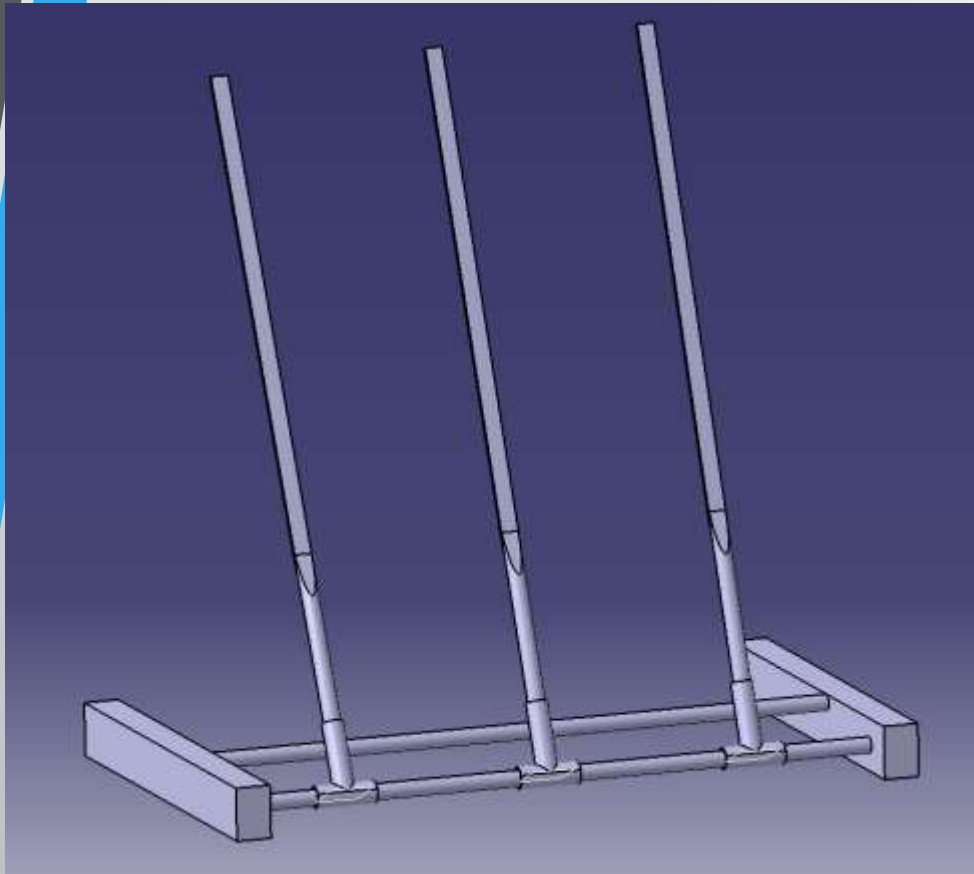

# Projektiranje proizvoda – AutoCAD

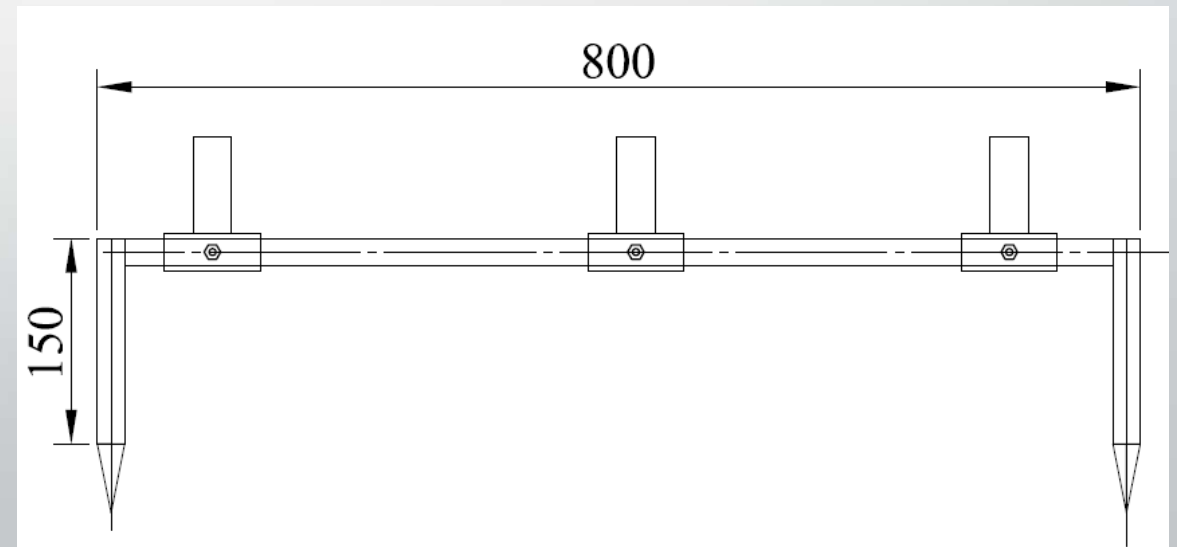
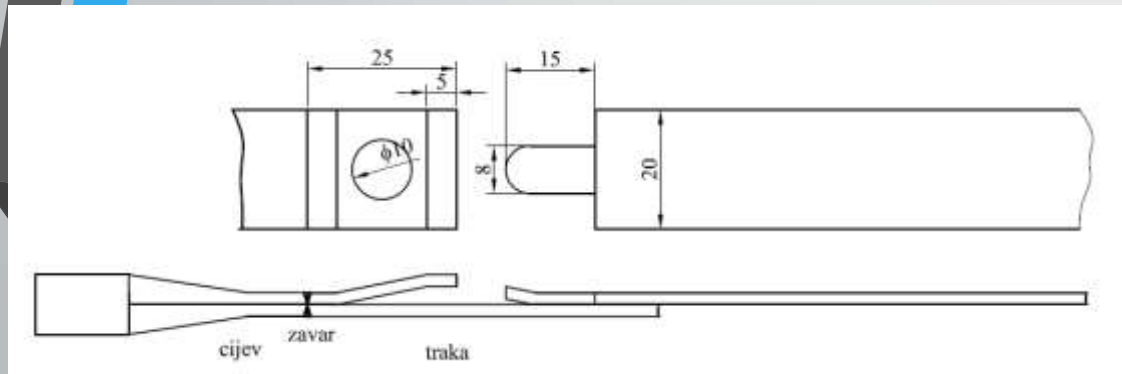
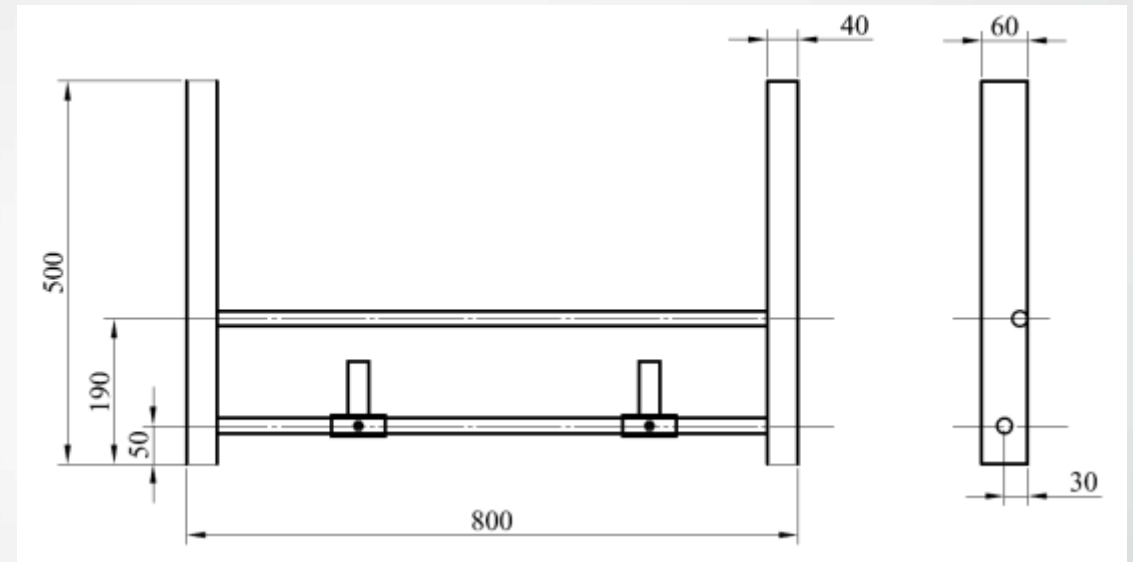
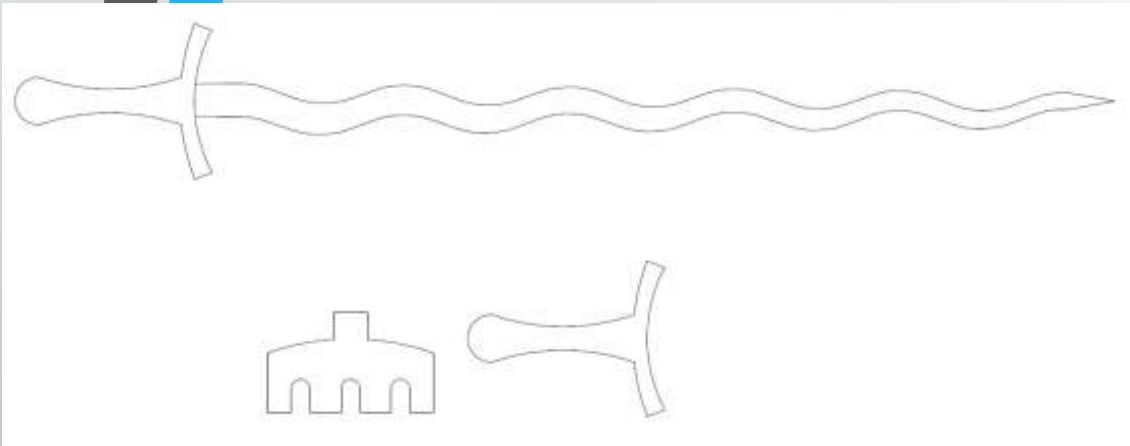

# Izrada prototipa proizvoda





# Izrada prototipa proizvoda



# Testiranje prototipa GASTRO-rašlji



# Testiranje prototipa GASTRO-rašlji



# Izrada serije GASTRO-rašlji od nehrđajućeg čelika



# Izrada serije GASTRO-rašlji od nehrđajućeg čelika



# Izrada serije GASTRO-rašlji od nehrđajućeg čelika

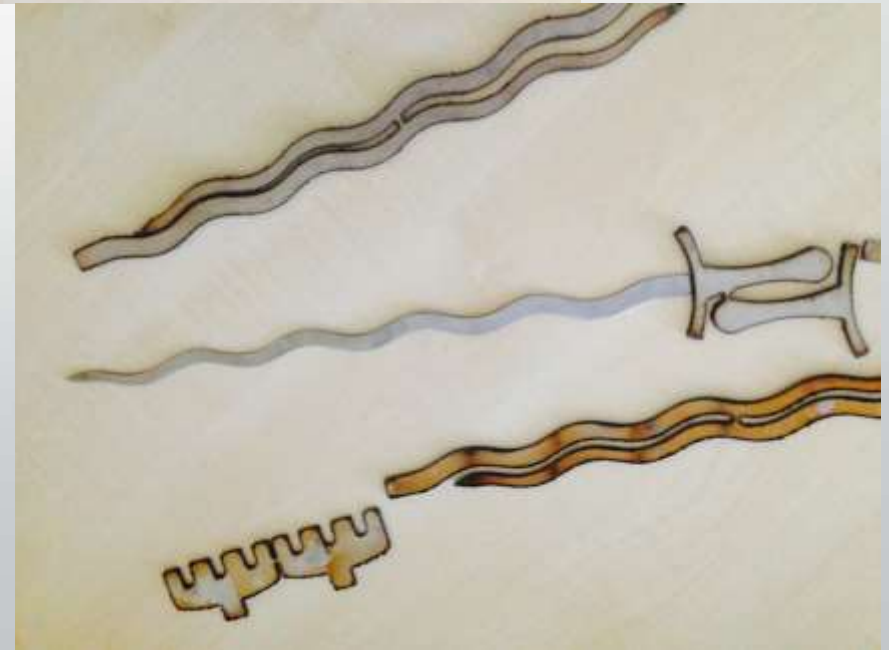

# Prezentacija proizvoda - Velika



# Prezentacija proizvoda - Velika

